



RESIDENTIAL SOLAR ENERGY SYSTEM APPLICATION CHECKLIST

RESIDENTIAL SOLAR ENERGY SYSTEM APPLICATION

The following items are required to be submitted as part of any Residential Solar Energy System Application:

1) PLANNING APPLICATION: Residential Solar Energy System Application

- Complete all sections (incomplete applications will delay processing time)
- Include all required plans/drawings/calculations listed in the application
- Homeowner's signature required
- If property is located in a homeowners association, complete HOA Approval Form at http://www.cerritos.us/RESIDENTS/_pdfs/hoa_approval_form.pdf

If you have any questions, please call the Planning Division at (562) 916-1201.

2) BUILDING PERMIT APPLICATION

- Complete all sections (incomplete applications will delay processing time)
- Complete Declaration Form
 - If owner-builder, complete columns 1 and 3
 - If contractor, complete columns 2 and 3

If you have any questions, please call the Building & Safety Division at (562) 916-1209.

New roof-mounted solar energy systems not exceeding 10KW DC are eligible for expedited, streamlined plan check review. If you would like to request expedited, streamlined plan check review, please ensure that the following documents are submitted, in addition to the Planning Application and Building Permit Application:

- County of Los Angeles Affidavit for Expedited Permitting of Small Residential Rooftop Solar Energy System Installation Form
- Ensure that your project satisfies all requirements of Section in the Residential Solar Energy Guidelines Manual

Submit forms together, with all required plans/drawings, at

https://cerritosca.seamlessdocs.com/f/Application_Plan_Submittal_Form

For more detailed information regarding the process for online submittal, please read the *Planning/Building Interim Electronic Submittal Procedure* at

http://www.cerritos.us/BUSINESSES/_pdfs/interim_electronic_submittal_procedure.pdf

3) BUSINESS LICENSE REQUIREMENT

If you are a contractor, you must have a valid City of Cerritos business license.

Please call the Business License Division at (562) 916-1236 to confirm active status or apply at

http://www.cerritos.us/BUSINESSES/business_licenses/contractor_business_license.php

The page is intentionally left blank.



RESIDENTIAL SOLAR ENERGY SYSTEM PLANNING APPLICATION

Residential solar energy systems are governed by Section 22.22.700(22)(c), "Solar Energy Systems," of the Cerritos Municipal Code, which is incorporated to this application by reference, and which is available on the City of Cerritos website at www.cerritos.us under GOVERNMENT » City Regulations » Cerritos Municipal Code » Title 22 » Chapter 22.22. Implementation standards for solar energy systems are set forth in this application.

1.0 HOMEOWNER INFORMATION

1.1 Name(s): _____ 1.2 Phone number: _____

1.3 Property address: _____

1.4 Is this property in a homeowners association (HOA)? Check one:

Yes No

This information is requested for record-keeping purposes. Section 65850.5(i) of the California Government Code states that a city shall not condition approval for any solar energy system permit on the approval by a homeowners association.

2.0 SOLAR ENERGY SYSTEM INFORMATION

2.1 Name of contractor/ entity performing work: _____ 2.2 State license #: _____

2.3 City business license #: _____ 2.4 Contact name: _____

2.5 Complete the solar energy system details requested below.

Proposed use for solar energy system:	<input type="checkbox"/> Electricity <input type="checkbox"/> Pool/spa <input type="checkbox"/> Space Heating	<input type="checkbox"/> Water heater <input type="checkbox"/> Other (specify): _____	
Solar energy system manufacturer:	Solar energy system unit name:	Existing roof area: sq. ft.	Size of solar energy system: sq. ft.

3.0 REQUIRED PLAN SPECIFICATIONS

Please reference the attached [Residential Solar Energy System Guidelines Manual](#) for requirements and recommendations for residential solar energy systems, as follows:

- **Section A:** Checklist of requirements for expedited, streamlined permitting
- **Section B:** Checklist of recommendations and design principles that are strongly suggested for incorporation into the plans outlined below.

Check the boxes below to acknowledge the submittal, with this completed application, of **two (2) copies** of plans as specified below (including all listed details).

- 3.1 Site plan (minimum 11" x 17") showing:
- 3.1a: Address of the residence, north arrow, and scale
 - 3.1d: Roof plan
 - 3.1e: Location of solar panels, rooftop disconnects and equipment, and wiring

Property address: _____
(same as item 1.3 on page 1)

FOR OFFICE USE ONLY	A/P# _____ <i>(Project Reference Number)</i>
----------------------------	---

- 3.2 Complete building elevations (minimum 11" x 17") showing:
 - 3.2a: All affected elevation views drawn to scale
 - 3.2b: Dimensioned profile of the solar panels
 - 3.2c: Dimensioned depiction of all electrical panels, meters, and other equipment associated with the solar energy system
 - 3.2d: Dimensioned depiction of all conduits, piping, or wiring on exterior walls

- 3.3 Solar panel installation details showing:
 - 3.3a: Manufacturer's specifications
 - 3.3b: Panels, pins/posts, mounting hardware, and electrical connections drawn to scale
 - 3.3c: Dimensioned depiction of the panel mounting
 - 3.3d: Roof materials and connections
 - » Generally, the portion of the roof under the solar panels shall not be changed to a different material than the remainder of the roof.
 - » If a different roof material is needed under the solar panels, it shall not be visible. Attach documentation explaining why the different roof material is needed and provide the additional required documents listed in Section 3.4 below.

- 3.4 (if applicable) If a different roof material is needed under the solar panels, the following additional documents shall be provided with this application.
 - 3.4a: Residential Re-Roofing Application for the new roof material. This document is available on the City of Cerritos website at www.cerritos.us under RESIDENTS » Permits / Applications for Home Improvements » Planning Applications and Information. Instructions:
 - » Fill out the application completely.
 - » Check "Yes" under question 2.9.
 - 3.4b: Notice Regarding Required Re-Roof Upon Future Solar Energy System Removal. The property owner is required to sign this Notice, which requires the restoration of said roof material to be consistent in style and color if the solar panel is ever removed in the future. This document is provided on page 4 of this application. Instructions:
 - » Fill in all blank lines.
 - » If the property is owned by a trust, then the document must be signed by the person(s) authorized by the trust. Under "Homeowner's name" type or print the title of the person signing (e.g., "Trustee of the Smith Family Trust").

- 3.5 Equipment floor plan (minimum 11" x 17") showing:
 - 3.5a: Dimensions and location of any associated equipment to be installed within the garage or elsewhere on the property, drawn to scale. (Equipment located in the garage shall not encroach into the required parking area.)
 - 3.5b: Label the room(s) or space where the equipment is installed

- 3.6 Completed standard electrical diagram for small-scale, single-phase PV systems:
 - 3.6a: Two (2) pages, attached to this application

4.0 BUILDING AND SAFETY APPLICATIONS

A Building/Plumbing/Electrical/Mechanical Permit Application from the Cerritos Building and Safety Division will also be required together with this Residential Solar Energy System Application. This application is available for download from the City of Cerritos website at www.cerritos.us under RESIDENTS » Permits / Applications for Home Improvements » Building and Safety Permit Applications and Information.

Property address: _____
(same as item 1.3 on page 1)

<p>FOR OFFICE USE ONLY</p> <p>A/P# _____ <i>(Project Reference Number)</i></p>
--

5.0 ACKNOWLEDGEMENT

By signing below, I acknowledge an understanding of the following declarations:

- 5.1 Compliance with Requirements for Expedited, Streamlined Permitting. I understand that, in order to be considered for expedited, streamlined permitting, the project and plans accompanying this application must meet the requirements of Section A of the attached Residential Solar Energy System Guidelines Manual.
- 5.2 Acknowledgement of Recommendations and Design Principles. I have read and understand Section B of the attached Residential Solar Energy System Guidelines Manual. I understand that the items listed in said Section B are not required but are strongly suggested in order to maintain consistency with the City's high quality design standards for residential properties.
- 5.3 Construction. Hours and days of construction are limited to the following:
 - Monday to Friday: 7am to 6pm
 - Saturday: 10am to 5pm
 - Sunday/City-Observed Holiday: No Work
- 5.4 Permit and Plan Adherence.
 - 5.4a: No work of any type shall take place unless all required permits are issued.
 - 5.4b: Approval of the submitted plans is subject to the applicant having submitted accurate dimensions and complete information. If, during construction, it is found that the approved plans did not have accurate dimensions and/or information, the City of Cerritos may require the work to cease until revised, accurate plans are submitted to the Department of Community Development for review in accordance with the requirements set forth herein.
 - 5.4c: All improvements shall be constructed in accordance with the approved plans. If, during construction, modifications or deviations from the approved plans are deemed necessary, any and all such modifications shall be submitted in the form of revised plans to the Department of Community Development for review in accordance with the requirements set forth herein. No modification or deviation shall proceed without prior written approval by the Department of Community Development. If these requirements are violated, the City of Cerritos may require the work to be completely removed and reconstructed in accordance with the approved plans.
- 5.5 Penalties for Violation. A violation of the statements and requirements of the Municipal Code may constitute an infraction punishable pursuant to Section 1.08.020 of the Cerritos Municipal Code.

I acknowledge and understand declarations 5.1 through 5.5 above.

5.6 Homeowner's signature: _____ Date: _____

5.7 Contractor's signature: _____ Date: _____

5.8 Property address: _____
(same as item 1.3 on page 1)

Property address: _____
(same as item 1.3 on page 1)

FOR OFFICE USE ONLY	A/P# _____ <i>(Project Reference Number)</i>
--------------------------------	--

FOR OFFICE USE ONLY

Planner check

- Application is complete and signed by both homeowner and contractor
- Review aerial photo to check proposal against existing conditions
- Project complies with CMC requirements
- Computer permit entry:
 - Check cases for existing notes and expired permits requiring resolution
 - Check that a permit is not already entered for this application and property
 - Computer codes: OVRTHECNTR » SLRENE
 - Property owner information is current (GIS); if not, request a copy of the grant deed to confirm ownership as a condition of permit issuance
 - Enter permit data

Project Ref. Number: A/P# _____

- Sign and date approval area
- Refer to Building and Safety Division for permit

City of Cerritos Planning Approval

Staff Signature

Date

Issuance of the permit shall not be construed as final approval of this installation. No final shall be issued unless all conditions of approval above have been completed.

**NOTICE REGARDING REQUIRED RE-ROOF
UPON FUTURE SOLAR ENERGY SYSTEM REMOVAL**
(Required if applicable under Section 3.4 of this application)

Cerritos Municipal Code Section 22.22.700(23), "Roofing" (the "Code"), requires that all visible roofing materials on the same residence shall match and be consistent in appearance. Your solar energy system installation entails the removal of certain portions of the existing tile roof material, and replacement with new sheathing and composition shingles in the location of the proposed photovoltaic solar panels. Pursuant to the Code, at such time in the future that the photovoltaic solar energy system is removed for any reason, roofing material covered by sheathing and composition shingle shall be replaced with new tile roofing to match the existing surrounding roof material in color and appearance, or the entire roof shall be replaced with one uniform roofing material in accordance with Cerritos Municipal Code standards. By signing this notice, you acknowledge your obligation, and agree to notify any future homeowner of this obligation. Please note that in some instances, your lease or power purchase agreement with your solar energy system company may obligate the solar energy system company to restore your roof on your behalf. If a violation of the Code occurs at any point, the City of Cerritos reserves the right to issue a citation of violation per Cerritos Municipal Code Chapter 1.10, and it is the responsibility of the homeowner of record at that point to resolve such violation.

Homeowner's signature: _____ Date: _____

Homeowner's name: _____

Property address: _____



RESIDENTIAL SOLAR ENERGY SYSTEM GUIDELINES MANUAL

This Residential Solar Energy System Guidelines Manual lists requirements and recommendations for residential solar energy systems.

Section A: Checklist of Requirements for Expedited, Streamlined Review & Permitting

In order to be considered for expedited, streamlined permitting, the proposed solar energy system must meet all requirements of Section A. This Section A satisfies the checklist requirement of California Government Code Section 65850.5(g), as amended under Assembly Bill 2188 (2014).

- A.1 State Law Definition.** The solar energy system is a "small residential rooftop solar energy system" as defined in California Government Code Section 65850.5(j)(3), which includes the provisions in checklist items A.2 through A.5 below.
- A.2 Size and Scope of Work.** The solar energy system is no larger than 10 kilowatts direct current (DC) nameplate rating or 30 kilowatts thermal. The scope of work does not include the proposal of a non-, roof-mounted solar energy system (ex. solar roof tiles) nor the proposal of an energy storage system (ESS).
- A.3 Code Compliance.** The solar energy system conforms to all applicable provisions and requirements of the County of Los Angeles Building, Electrical, Mechanical, and Plumbing Codes, adopted by reference by the City of Cerritos in Cerritos Municipal Code Chapters 15.04, 15.12, 15.16, and 15.20, respectively.
- A.4 Single-Family Dwelling.** The solar energy system is installed on a permitted single-family dwelling.
- A.5 Height.** The solar panel(s) or module array(s) does/do not exceed the maximum legal building height for the subject zone.

Section B: Checklist of Recommendations and Design Principles

This Section B lists recommendations and design principles of the City of Cerritos for residential solar energy systems. The following items are not required but are strongly suggested in order to maintain consistency with the City's high quality design standards for residential properties.

- B.1 Minimize Visible Conduits.** Visible conduits, piping, or wiring should be minimized to the extent feasible.
- B.2 Wiring Through Attic.** Wiring should be routed under the solar panel/array into the roof and through the attic. When applicable, said wiring shall be located a minimum of 18" below the attic ceiling to comply with life safety requirements.
- B.3 Short Conduit Runs Across Roof.** No conduit, piping, or wiring should extend across the roof more than 5'-0". If there is no attic, then panels should be sited to minimize conduit runs across the roof to the extent feasible, with no conduit runs greater than 5'-0" across the roof.
- B.4 No Conduit Over Roof Ridge.** No conduit, piping, or wiring should extend over a roof ridge.
- B.5 No Conduit Around Roof Eave.** No conduit should wrap around a roof eave; instead, conduits should be routed through the roof eave to the vertical wall below.

- B.6 Paint Conduits to Match Surface. All conduits should be painted to match the color of the surface on which they are mounted.
- B.7 Paint Equipment to Match Surface. Electrical panels, meters, and other equipment should be painted to match the color of the surface on which they are mounted.
- B.8 Vertical Conduit Runs. Vertical conduit runs should be sited and located in such a manner to minimize visibility from public streets and, if feasible, from adjacent properties, such as along a chimney, along a rain gutter, along an architectural projection, or at the intersection of two building planes. To the maximum extent feasible, conduits should not run vertically across the middle of a flat stucco plane, but rather at the plane edges or at prominent architectural transition areas. If no such architectural transition areas exist, the conduit should be run across the shortest vertical distance. (See Exhibit A attached to this checklist.)
- B.9 Horizontal Conduits Along Roof Eave. Horizontal conduits, if needed in order to connect the wiring from the attic/roof to the vertical conduit, should run immediately adjacent to and under the roof eave to arrive at the preferred vertical conduit location described above, so as to minimize visibility. If running adjacent to and under the roof eave is infeasible, then the horizontal conduit should run along the base of the building as described below.
- B.10 Horizontal Conduits Along Building Base. Horizontal conduits that connect the vertical conduit to electrical panels should run along the base of the building above the weep screed or, if infeasible, as low as possible below the height of the perimeter block walls.
- B.11 Tidy Grounding Wire Conduit Installation. Grounding wire and its flexible conduit should be installed in a tidy fashion, with straight vertical and horizontal runs, along its entire length. Said conduit should follow the same guidelines above regarding painting and location.
- B.12 Low-Profile Panels. Panel installations should have a low-profile, flush-mounted design. The smallest gap feasible is encouraged between the solar panel and the roof material, and said gap should be a maximum of 6".
- B.13 Consistent Roof Material. Generally, the portion of the roof under the solar panels shall not be changed to a different material than the remainder of the roof. If a different roof material is needed under the solar panels, it should not be visible. In such a case, a Residential Re-Roofing Application will be required for the new material, which is available on the City of Cerritos website at www.cerritos.us under RESIDENTS » Permits / Applications for Home Improvements » Planning Applications and Information. The property owner will be required to record a covenant requiring the restoration of said roof material to its original style and color if the solar panel is ever removed in the future.
- B.14 Equipment in Garage. Equipment located in the garage should be placed so as not to encroach into the required parking area.
- B.15 Exterior Equipment Height. Equipment mounted on the face of exterior walls of the residence should be no higher than 6'-0" from the finish grade.

Exhibit A: Vertical Conduit Run Illustration

This exhibit is illustrative. Submitted drawings should reflect actual site conditions.

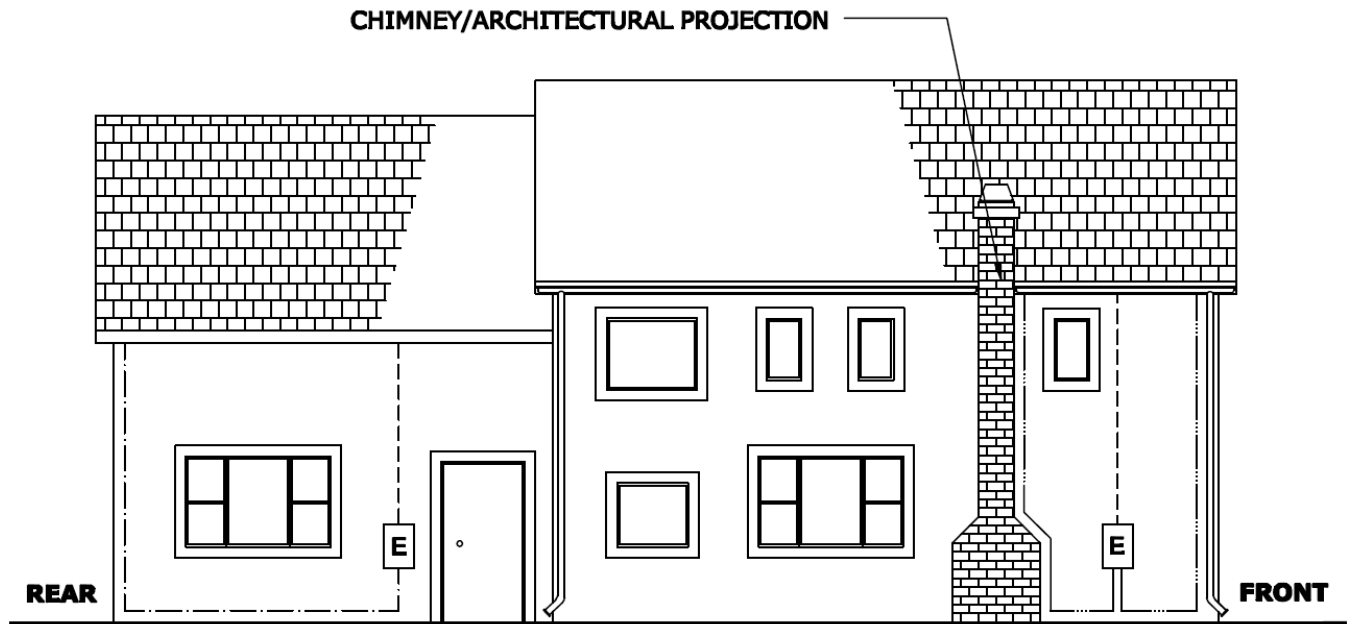

LEGEND

- PREFERRED CONDUIT RUN
- - - - ACCEPTABLE CONDUIT RUN
- · · · DISCOURAGED CONDUIT RUN: NOT PERMITTED
IF OTHER FEASIBLE ALTERNATIVES EXIST

E EQUIPMENT BOX

The page is intentionally left blank.

EQUIPMENT SCHEDULE			
TAG	DESCRIPTION	PART NUMBER	NOTES
1	SOLAR PV MODULE		
2	PV ARRAY		
3	J-BOX (IF USED)		
4	COMBINER (IF USED)		
5	DC DISCONNECT		
6	DC/AC INVERTER		
7	AC DISCONNECT (IF USED)		
8	GEN METER (IF USED)		
9	SERVICE PANEL		

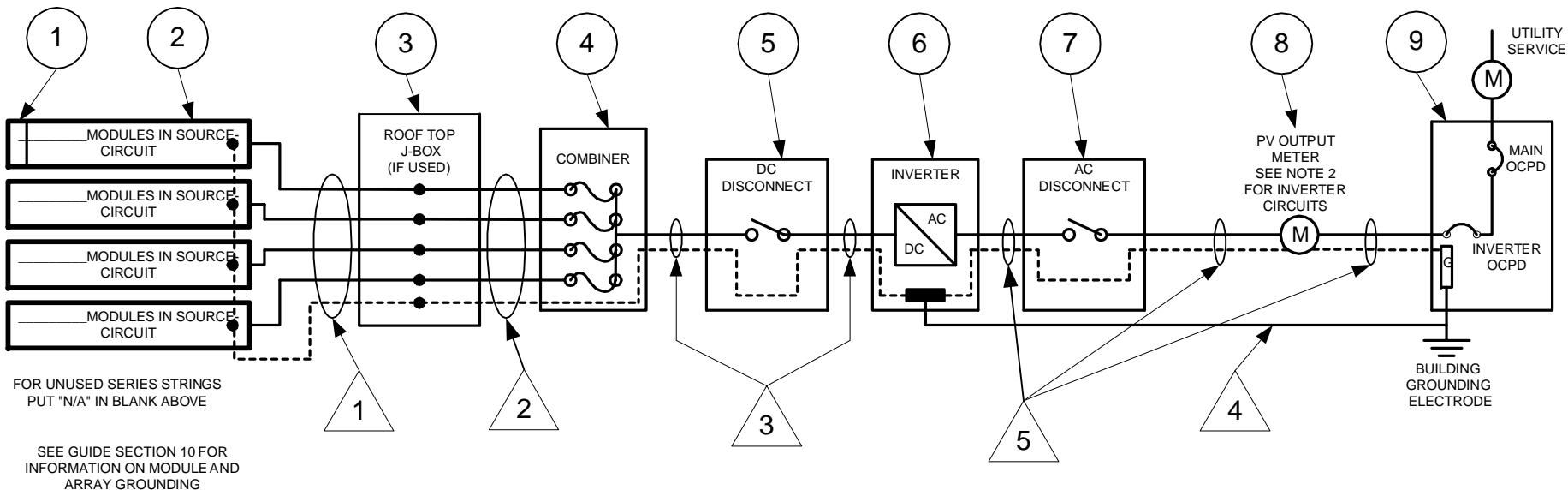

STANDARD ELECTRICAL DIAGRAM FOR SMALL-SCALE, SINGLE-PHASE PV SYSTEMS

SITE NAME:

SITE ADDRESS:

SYSTEM AC SIZE:

CONTRACTOR / ENG. NAME:

CONTRACTOR / ENG. ADDRESS:

CONTRACTOR / ENG. LIC # : **EXPIRATION DATE:**

DRAWN BY: **DATE:** **DRAWING NO:**

CONDUIT AND CONDUCTOR SCHEDULE					
Δ TAG	DESCRIPTION OF CONDUCTOR TYPE	Cond. Gauge	# of Conductors	Conduit Type	Conduit Size
1	USE-2 OR PV WIRE(UF, SE, USE)				
	BARE COPPER EQ. GND. COND.(EGC)				
2	THWN-2 OR XHHW-2 (circle one)				
3	THWN-2 OR XHHW-2 (circle one)				
	INSULATED EGC				
4	DC GROUNDING ELECTRODE COND.				
5	THWN-2 OR XHHW-2 (circle one)				
	INSULATED EGC				

PV MODULE RATINGS	
MODULE MAKE	
MODULE MODEL	
MAX. POWER POINT CURRENT (Imp)	
MAX. POWER POINT VOLTAGE (Vmp)	
OPEN-CIRCUIT VOLTAGE (Voc)	
SHORT-CIRCUIT CURRENT (Isc)	
MAX. SERIES FUSE (OCPD)	
MAX. POWER (Pmax)	
MAX. VOLTAGE (TYP 600 VDC)	

NOTES FOR ALL DRAWINGS

OCPD=OVERCURRENT PROTECTION DEVICE

NATIONAL ELECTRICAL CODE REFERENCES SHOWN AS (NEC XXX.XX)

INVERTER RATINGS

INVERTER MAKE	
INVERTER MODEL	
MAX. DC VOLT RATING	
MAX POWER @40°C	
NOMINAL AC VOLTAGE	
MAX AC CURRENT	
MAX OCPD	

SIGNS

SIGN FOR DC DISCONNECT	
PHOTOVOLTAIC POWER SOURCE	
RATED MPP CURRENT	
RATED MPP VOLTAGE	
MAX. SYSTEM VOLTAGE	
MAX CIRCUIT CURRENT	
WARNING ELECTRICAL SHOCK HAZARD-LINE AND LOAD MAY BE ENERGIZED IN OPEN POSITION	
SIGN FOR INVERTER OCPD AND AC DISCONNECT (IF USED)	
AC POINT OF CONNECTION	
AC OUTPUT CURRENT	
NOMINAL AC VOLTAGE	

NOTES FOR ARRAY CIRCUIT WIRING

1) LOWEST EXPECT AMBIENT TEMPERATURE BASED ON ASHRAE MINIMUM MEAN EXTREME DRY BULB TEMPERATURE FOR ASHRAE LOCATION MOST SIMILAR TO INSTALLATION. LOWEST EXPECTED AMBIENT TEMP 0 °C

2) HIGHEST CONTINUOUS AMBIENT TEMPERATURE BASED ON ASHRAE HIGHEST MONTH 2% DRY BULB TEMPERATURE FOR ASHRAE LOCATION MOST SIMILAR TO INSTALLATION LOCATION. HIGHEST CONTINUOUS TEMPERATURE 34 °C

3) 2005 ASHRAE FUNDAMENTALS 2% DESIGN TEMPERATURES DO NOT EXCEED 47°C IN THE UNITED STATES (PALM SPRINGS, CA IS 44.1°C). FOR LESS THAN 9 CURRENT-CARRYING CONDUCTORS IN ROOF-MOUNTED SUNLIT CONDUIT AT LEAST 1/2" ABOVE ROOF AND USING THE OUTDOOR DESIGN TEMPERATURE OF 47°C OR LESS (ALL OF UNITED STATES),

a) 12 AWG 90°C CONDUCTORS ARE GENERALLY ACCEPTABLE FOR MODULES WITH Isc OF 7.68 AMPS OR LESS WHEN PROTECTED BY A 12 AMP OR SMALLER FUSE

b) 10 AWG 90°C CONDUCTORS ARE GENERALLY ACCEPTABLE FOR MODULES WITH Isc OF 9.6 AMPS OR LESS WHEN PROTECTED BY A 15 AMP OR SMALLER FUSE

NOTES FOR INVERTER CIRCUITS

1) IF UTILITY REQUIRES A VISIBLE-BREAK SWITCH, DOES THIS SWITCH MEET THE REQUIREMENT? YES / NO (CIRCLE ONE)

2) IF GENERATION METER REQUIRED, DOES THIS METER SOCKET MEET THE REQUIREMENT? YES / NO (CIRCLE ONE)

3) SIZE PHOTOVOLTAIC POWER SOURCE (DC) CONDUCTORS BASED ON MAX CURRENT ON 690.53 SIGN OR OCPD RATING AT DISCONNECT (IF SUPPLIED)

4) SIZE INVERTER OUTPUT CIRCUIT (AC) CONDUCTORS ACCORDING TO INVERTER OCPD AMP RATING

5) TOTAL OF ___ INVERTER OCPD(S), ONE FOR EACH INVERTER. DOES TOTAL SUPPLY BREAKERS COMPLY WITH 120% BUSBAR EXCEPTION IN 690.64(B)(2)(a)? YES / NO (CIRCLE ONE)

STANDARD ELECTRICAL DIAGRAM FOR SMALL-SCALE, SINGLE-PHASE PV SYSTEMS

SITE NAME:

SITE ADDRESS:

SYSTEM AC SIZE:

CONTRACTOR / ENG. NAME:

CONTRACTOR / ENG. ADDRESS:

CONTRACTOR / ENG. LIC # :

EXPIRATION DATE:

DRAWN BY:

DATE:

DRAWING NO:



City of Cerritos
 18125 Bloomfield Avenue
 Cerritos, CA 90703
 (562) 916-1209

**Department of Community
 Development**
 Building and Safety Division

(For office use only)

Building Permit #: _____

Trade Permit #: _____

Parent Permit#: _____

Building/Plumbing/Electrical/Mechanical Permit Application

Applicant's Name: _____

Company Name (if applicable): _____

Tel. No: _____ Email: _____ Date: _____

Job Site Address: _____ Suite: _____

Work Description: _____

Is this an owner-builder project?

Yes, this is an owner-builder project. As the applicant for an owner-building project, you are required to complete columns 1 and 3 of attached Declaration Form.

Is the job site address your primary residence? Yes No (If no, an owner-builder project is not permitted, and the owner must contract exclusively with a licensed contractor.)

No, this is not an owner-builder project. Complete columns 2 and 3 of the attached Declaration Form.

Project Valuation: _____ APN#: _____

Project Size (sq.ft.): _____ Buildings on Lot: _____ # of Stories _____

Construction Types: _____ Occupancy Groups: _____

Type of Permit(s) Requested: Building Plumbing Electrical Mechanical

Owner/Business Name: _____

Street Address: _____

City: _____ State: _____ Zip Code: _____

Telephone Number: _____ Email: _____

Contractor Name: _____ **Company:** _____

Street Address: _____

City: _____ State: _____ Zip Code: _____

Telephone Number: _____ Email: _____

License No: _____ Class: _____ Expiration Date: _____

City Business License No: _____ Expiration Date: _____

(Please fill out attached Licensed Contractor's Declaration Form)

Architect/Engineer Name: _____ **Company:** _____

Street Address: _____

City: _____ State: _____ Zip Code: _____

Telephone Number: _____

License No: _____ Class: _____ Expiration Date: _____

JOB ADDRESS
LOCALITY

COLUMN 1

OWNER-BUILDER DECLARATION

I hereby affirm under penalty of perjury that I am exempt from the Contractors' State License Law for the reason(s) indicated below by the checkmark(s) I have placed next to the applicable item(s) (Section 7031.5, Business and Professions Code): Any city or county that requires a permit to construct, alter, improve, demolish, or repair any structure, prior to its issuance, also requires the applicant for the permit to file a signed statement that he or she is licensed pursuant to the provisions of the Contractors' State License Law (Chapter 9 (commencing with Section 7000) of Division 3 of the Business and Professions Code) or that he or she is exempt from licensure and the basis for the alleged exemption. Any violation of Section 7031.5 by any applicant for a permit subjects the applicant to a civil penalty of not more than five hundred dollars (\$500.)

() I, as owner of the property, or my employees with wages as their sole compensation, will do () all of or () portions of the work, and the structure is not intended or offered for sale (Section 7044, Business and Professions Code: The Contractors' State License Law does not apply to an owner of property who, through employees' or personal effort, builds or improves the property, provided that the improvements are not intended or offered for sale. If, however, the building or improvement is sold within one year of completion, the Owner-Builder will have the burden of proving that it was not built or improved for the purpose of sale.)

() I, as owner of the property, am exclusively contracting with licensed Contractors to construct the project (Section 7044, Business and Professions Code. The Contractor's State License Law does not apply to an owner of property who builds or improves thereon, and who contractors for the projects with a license Contractor pursuant to the Contractors' State License Law.)

() I am exempt from licensure under the Contractors' State License Law for the following reason:

By my signature below I acknowledge that, except for my personal residence in which I must have resided for at least one year prior to completion of the improvements covered by this permit, I cannot legally sell a structure that I have built as an owner-builder if it has not been constructed in its entirety by licensed contractors. I understand that a copy of the applicable law, Section 7044 of the Business and Professions Code, is available upon request when this application is submitted or at the following Web site: <http://www.leginfo.ca.gov/calaw.html>.

Date: _____

Signature of Property Owner or Authorized Agent

COLUMN 2

LICENSED CONTRACTOR'S DECLARATION

I hereby affirm under penalty of perjury that I am licensed under provisions of Chapter 9 (commencing with Section 7000) of Division 3 of the Business and Professions Code, and my license is in full force and effect.

License Class _____ License No. _____

Date _____ Contractor Signature _____

WORKERS' COMPENSATION DECLARATION

WARNING: FAILURE TO SECURE WORKER'S COMPENSATION COVERAGE IS UNLAWFUL AND SHALL SUBJECT AN EMPLOYER TO CRIMINAL PENALTIES AND CIVIL FINES UP TO ONE HUNDRED THOUSAND DOLLARS (\$100,000), IN ADDITION TO THE COST OF COMPENSATION, DAMAGES ARE PROVIDED FOR IN SECTION 3706 OF THE LABOR CODE, INTEREST, AND ATTORNEY'S FEES.

I hereby affirm under penalty of perjury one of the following declarations:

I have and will maintain a certificate of consent to self-insure for workers' compensation, issued by the Director of Industrial Relations as provided for by Section 3700 of the Labor Code, for the performance of the work for which this permit is issued.

Policy No. _____

I have and will maintain workers' compensation insurance, as required by Section 3700 of the Labor Code, for the performance of the work for which this permit is issued. My workers' compensation insurance carrier and policy number are:

Carrier	Policy Number	Expiration Date
_____	_____	_____

Name of Agent	Phone Number
_____	_____

I certify that, in the performance of the work for which this permit is issued, I shall not employ any person in any manner so as to become subject to the workers' compensation laws of California, and agree that, if I should become subject to the workers' compensation provisions of Section 3700 of the Labor Code, I shall forthwith comply with those provisions

Signature of Applicant

Date

COLUMN 3

HAZARDOUS MATERIAL DECLARATION

Will the applicant or future building occupant handle a hazardous material or a mixture containing a hazardous material equal to or greater than the amount specified on the hazardous material information guide?

Yes No

Will the intended use of the building by the applicant or future building occupant require a permit for construction or modification from the South Coast Air Quality Management District (SCAQMD)? See permitting checklist for guidelines.

Yes No

I have read the hazardous materials information guide and the SCAQMD permitting checklist. I understand my requirements under the Los Angeles County Code Title 2, Chapter 220 Sections 220.100 through 220.140 concerning hazardous material reporting and for obtaining a permit from the SCAQMD.

ASBESTOS NOTIFICATION

Notification letter sent to SCAQMD or EPA

I declare that notification of asbestos removal is not applicable to addressed project.

DECLARATION REGARDING CONSTRUCTION LENDING AGENCY

I hereby affirm under penalty of perjury that there is a Construction lending agency for the performance of the work for which this permit is issued (Section 3097, Civil Code)

Lender's Name

Lender's Address

By my signature below, I certify to each of the following:
I am the property owner or authorized to act on the property owner's behalf.

I have read this application and the information I have provided is correct.

I agree to comply with all applicable city and county ordinances and state laws relating to building construction.

I authorize representatives of this county to enter the above-identified property for inspection purposes.

Signature of Property Owner or Authorized Agent

Date

The page is intentionally left blank.



**COUNTY OF LOS ANGELES
DEPARTMENT OF PUBLIC WORKS
BUILDING AND SAFETY DIVISION**

Form A

AFFIDAVIT FOR EXPEDITED PERMITTING OF SMALL RESIDENTIAL ROOFTOP SOLAR ENERGY SYSTEM INSTALLATION

Date: _____

Project Address: _____

APN: _____ - _____

Property Owner's Declaration

I, _____ (print full name), legal owner of the above mentioned property, certify and declare under penalty of perjury, that I am aware that the proposed solar energy system at this site shall be installed only on a structure built with the appropriate permits and approvals. I am aware that if the County of Los Angeles determines that the solar energy system has been installed on an unpermitted structure as required by the Building Code, the Building Official shall order that the solar energy system and the structure be removed within 45 days or permits be obtained to bring the structure into compliance with current codes, within 45 days. I am aware that failure to comply with any order issued by the Building Official shall result in code enforcement action and a Notice of Violation may be recorded against the property title.

The County shall not, in any way, be liable or responsible for any costs and I shall indemnify the County from and against any and all claims and expenses, including reasonable attorney's fees, in connection with any requested action and/or liability related to the required removal a solar energy installation system.

Property Owner's Information

Name: _____

Address: _____

Telephone Number: _____

Signature: _____

Solar Company Representative's Declaration

I, _____(print full name), the legal representative of the solar energy system installation company _____(print company name), certify and declare under penalty of perjury that I am aware that the proposed solar energy system at this site shall be installed only on a structure built with the appropriate permits and approvals. We have reviewed the site and all available public records relating to building permits and approvals to verify that the installation will be placed on a permitted structure. In the event that the solar energy system is determined to have been installed on an unpermitted structure, _____(print company name) will be responsible for the relocation or removal of the system.

The County shall not, in any way, be liable or responsible for any costs and I shall indemnify the County from and against any and all claims and expenses, including reasonable attorney's fees, in connection with any requested action and/or liability related to the required removal a solar energy installation system.

Solar Company Information

Name: _____

Address: _____

Company Representative: _____

Telephone Number: _____

Signature: _____



**COUNTY OF LOS ANGELES
DEPARTMENT OF PUBLIC WORKS
BUILDING AND SAFETY DIVISION**

Form B

AFFIDAVIT FOR EXPEDITED PERMITTING OF SMALL RESIDENTIAL ROOFTOP SOLAR ENERGY SYSTEM INSTALLATION

Date: _____

Project Address: _____

APN: _____ - _____

Owner Builder Declaration

I, _____ (print full name), legal owner of the above mentioned property, certify and declare under penalty of perjury that I am aware that the proposed solar energy system at this site shall be installed only on a structure built with the appropriate permits and approvals. I have reviewed all available public records relating to building permits and approvals to verify that the installation will be placed on a permitted structure. I am aware that if the County of Los Angeles determines that the solar energy system has been installed on an unpermitted structure, the Building Official shall order that the solar energy system and the structure be removed within 45 days or permits be obtained to bring the structure into compliance with current codes, within 45 days. I am aware that failure to comply with any order issued by the Building Official shall result in code enforcement action and a Notice of Violation may be recorded against the property title.

The County shall not, in any way, be liable or responsible for any costs and I shall indemnify the County from and against any and all claims and expenses, including reasonable attorney's fees, in connection with any requested action and/or liability related to the required removal a solar energy installation.

Name: _____

Address: _____

**Telephone
Number:** _____

Signature: _____

The page is intentionally left blank.



**COUNTY OF LOS ANGELES
DEPARTMENT OF PUBLIC WORKS
BUILDING AND SAFETY DIVISION**

Form C

AFFIDAVIT FOR EXPEDITED PERMITTING OF SMALL RESIDENTIAL ROOFTOP SOLAR ENERGY SYSTEM INSTALLATION

Date: _____

Project Address: _____

APN: _____ - _____

Solar Company Representative's Declaration

I, _____ (print full name), the representative of the solar energy system installation company _____ (print company name), certify and declare that the proposed solar energy system at this site shall be installed only on a structure built with the appropriate permits and approvals, and I am not aware of any deficiency in required permits or approvals for the structure on which the solar energy system is being installed. We have reviewed the site and the building permits to verify that the installation will be placed on a permitted structure.

In the event that the solar energy system is determined to have been installed on an unpermitted structure which lacks required permits or inspection approvals, _____ (print company name) will be responsible for the relocation or removal of the solar energy system upon County issuance of a correction or violation notice.

The County shall not, in any way, be liable or responsible for any costs and/or claims and expenses, including attorney's fees, in connection with any requested action and/or liability related to the required removal a solar energy installation system.

Solar Company Information

Name of solar company: _____

Address: _____

Name of Authorized Company

Representative: _____

Telephone No.: _____

Signature of Authorized Company

Representative: _____

The page is intentionally left blank.